



REVERSER KIT [A292] FOR MKX100, X100 AND HX100 SERIES AUGER MODELS INSTALLATION INSTRUCTIONS



Read and understand the safety information in the auger manual before proceeding.



Read and understand the instructions in this manual before attempting to install this product.



Refer to the auger manual for operation instructions.

PRE-INSTALLATION INSTRUCTIONS

1. Lower the auger to full down position, and disconnect the tractor from the auger (PTO shaft, hydraulic lines, and hitch).
2. Chock the auger wheels to prevent rolling.
3. Lower the swing hopper fully to the ground.
4. Remove the PTO driveline from the auger.
5. Remove the sprocket shield from the boot.
6. Remove the drive chain from the front of the boot.

REVERSER KIT INSTALLATION

1. Locate mounting holes “X” and “Y” (see Figure 1). Knock the steel plugs out of these holes using a punch and hammer.

Note: *If the boot does not have the required holes for mounting the reverser bracket, drill the holes using the provided template (see Figure 2) or contact customer service for further assistance.*

2. Install the reverser base with two 1/2" x 1" bolts and locknuts (see Figure 3). Do not tighten until step 5.
3. Install the half-link on roller chain and place chain over upper and lower sprockets, passing it through the reverser base.

Westfield | Wheatheart

part of the Ag Growth International group
P.O. Box 39, Rosenort, Manitoba, R0G 1W0 Canada
Ph: (866) 467-7207 or (204) 746-2396 Fax: (866) 768-4852
Website: www.grainaugers.com | www.wheatheart.com
Email: sales@grainaugers.com | sales@wheatheart.com

Hutchinson | Mayrath

part of the Ag Growth International group
514 W. Crawford St., Clay Center, Kansas, 67432 USA
Ph: (800) 523-6993 or (785) 632-2161 Fax: (785) 632-5964
Website: www.hutchinson-mayrath.com
Email: sales@hutchinson-mayrath.com

© Ag Growth International Inc. 2018

PART NUMBER: 30910 R2

REVISED: 28/11/18

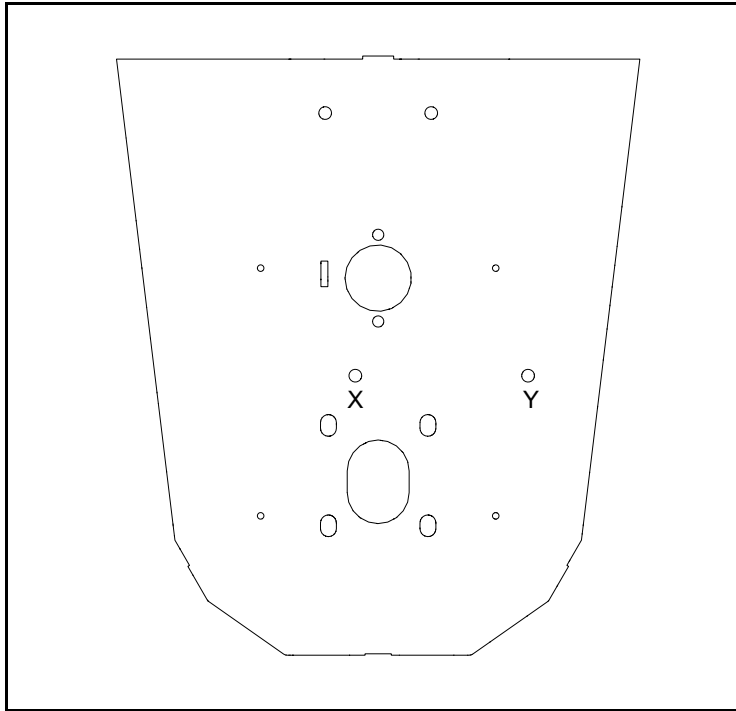

Figure 1 Locating Reverser Bolt Holes

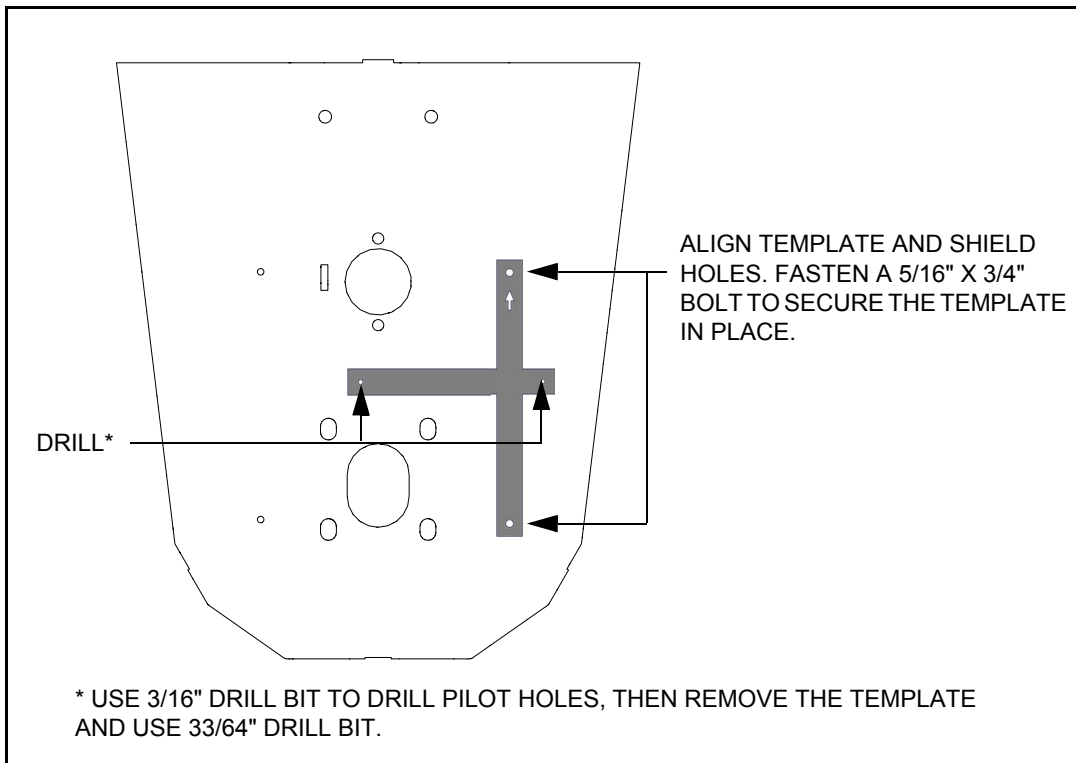

Figure 2 Drilling Reverser Bolt Holes Using Template

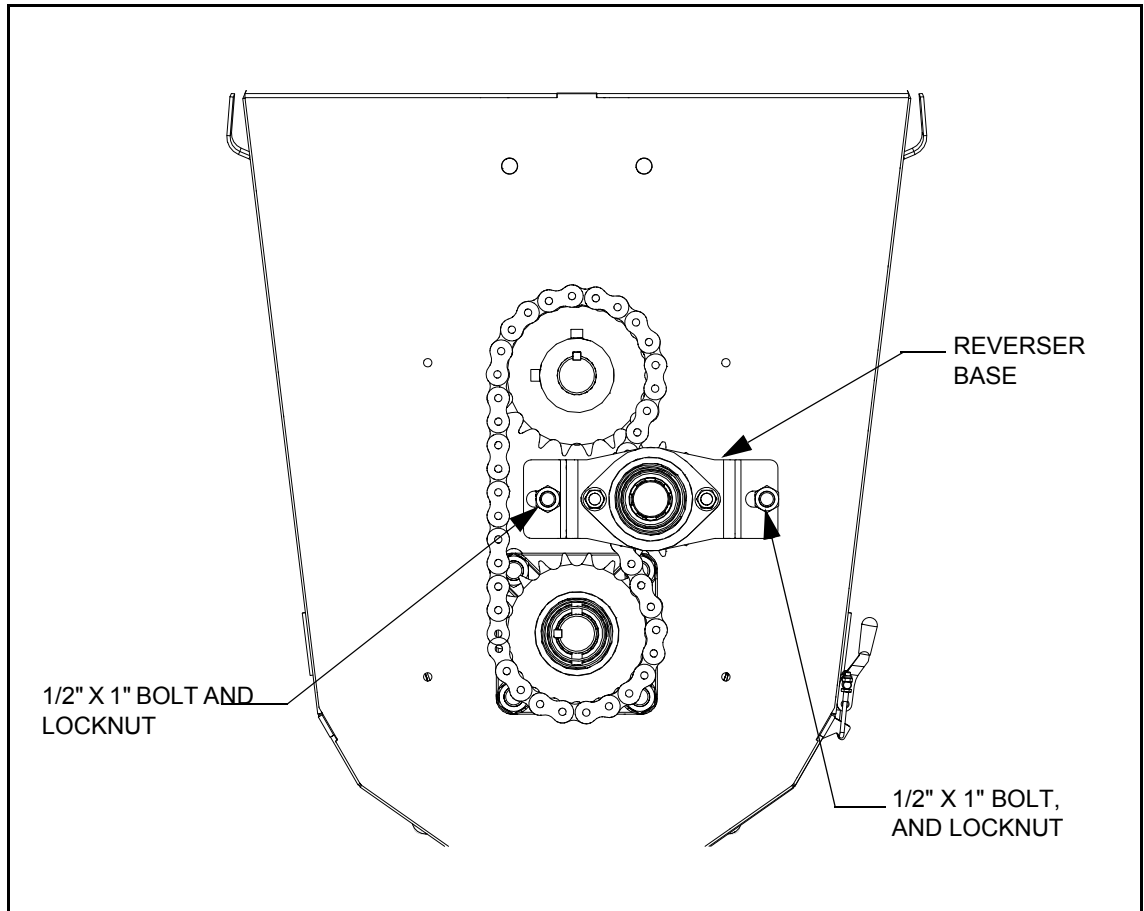



Figure 3 Fastening Reverser Base to the Boot

4. Join the two ends of the chain together using the half link and the connector link.
5. Push the reverser base against the chain as tight as possible and tighten the two 1/2" x 1" bolts.

Note: *It may be necessary to loosen the lower bearing and raise the lower sprocket to get proper chain wrap on the reverser sprocket.*

6. Install the lower coupler on the flight shaft using a 1/4" x 3-3/8" square key and secure using a 5/16" x 2" roll pin (see Figure 4).
7. Facing the front of the boot, install the shield bracket onto the upper right boot mounting hole using one original 5/16" x 3/4" bolt.

CAUTION	
	<p>Protect your eyes when tapping in the roll pin.</p>

8. Attach the new (longer) PTO bracket to front of boot face with the original 1/2" x 1-1/4" bolts and locknuts.
9. Fasten hitch extension to tow bar with one 3/4" x 2" bolt, flat washer, and locknut, and one 5/8" x 4-1/2" bolt and locknut.
10. Install the splined stub shaft on the PTO driveline using a 1/4" x 1-1/2" square key and 5/16" x 2" roll pin. Use a thread locking compound on setscrews to install and tighten them securely.
11. Install the new reverser shield using the three remaining original 5/16" x 3/4" bolts. Discard the old sprocket shield.

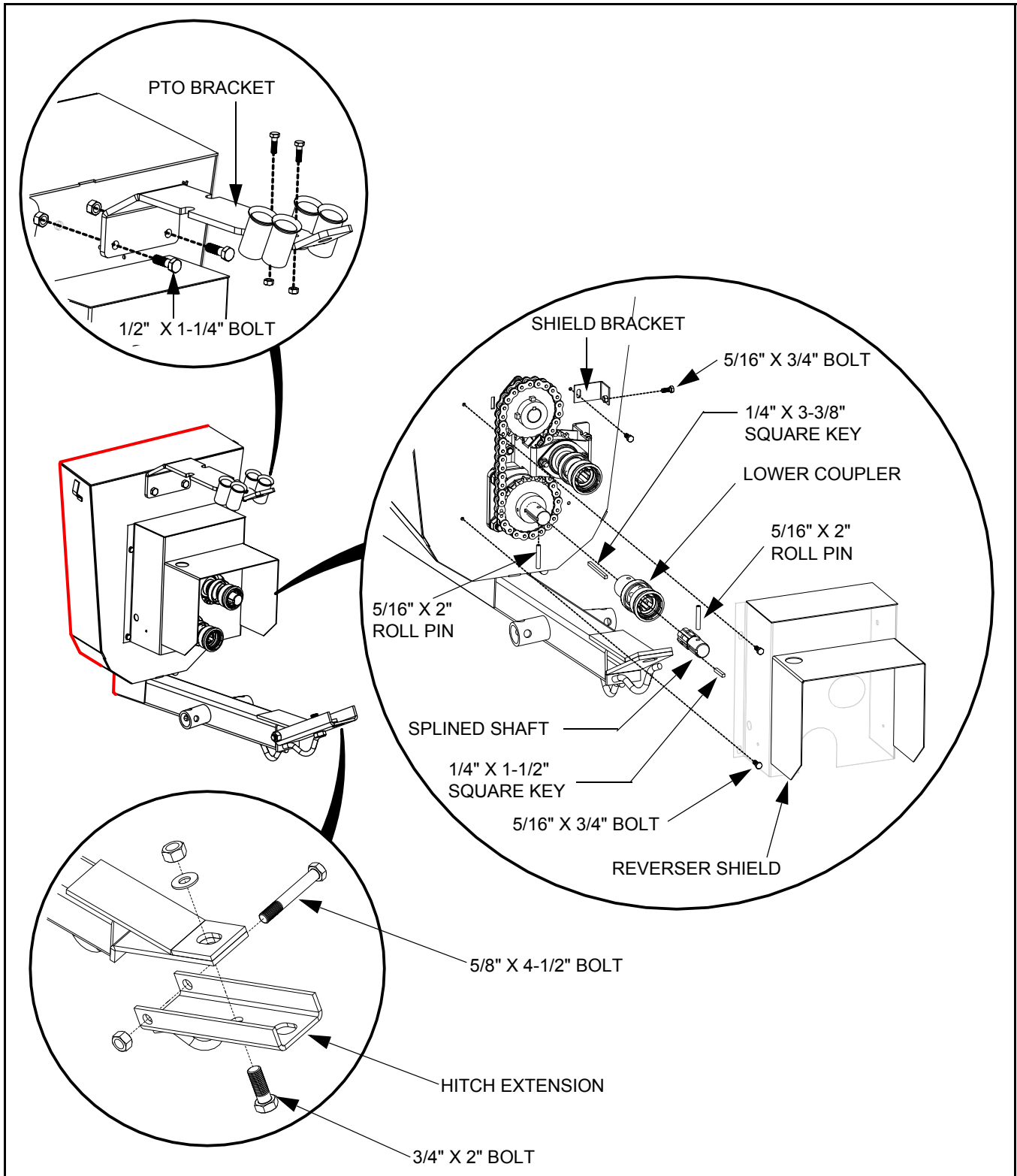

Figure 4 Reverser Assembly Details (Splined Shaft, Coupler, Shield, and Hardware)